

# HG250G

## DEMAND COMPACT

The Hyde GUARDIAN Gold™ Ballast Water Treatment system is an effective and reliable solution combining filtration with Ultraviolet (UV) disinfection.

### HG250G Features:

- Smallest footprint on the market
- Seven automatic modes of operation allowing one-touch operation
- Automatic backflushing filter capable of handling heavy organic and sediment loading
- Operates independent of salinity, temperature or hold time
- Produces no harmful disinfection by-products

### What's Included:

- Filter
- UV Chamber
- Control Panel
- Power Panel
- Control valves
- Flow meter
- Air supply regulator

### Options available:

- Skid mounting (includes interconnect piping and wiring)
- Hazardous Area certification available
- Remote panels
- Easy interface with ships automation
- Isokinetic Sample Port(s)
- Gravity operation



The HG250GS assembly mounts major components providing the most compact solution available.

| Technical Data             |                              |
|----------------------------|------------------------------|
| Treatment Rated Capacity   | 250 m <sup>3</sup> /hr       |
| Electrical Supply          | 380 – 690V · 50/60 Hz · 3 ph |
| Power Consumption          | 18 kW Nominal (25 kW max)    |
| Max. Operating Pressure    | 10 bar                       |
| Minimum Flow               | 25 m <sup>3</sup> /hr        |
| Max. Operating Temperature | 55° C                        |

| Component                | Size (L · W · H)<br>(mm) | Weight<br>(kg) |
|--------------------------|--------------------------|----------------|
| Skid (Complete Assembly) | 1617 · 1063 · 2241       | 1275           |
| Filter                   | 464 · 493 · 1146         | 288            |
| UV Chamber               | 1075 · 949 · 587         | 165            |
| Control Panel            | 600 · 210 · 760          | 35             |
| Power Panel              | 1206 · 406 · 1803        | 415            |

FRONT VIEW

SIDE VIEW

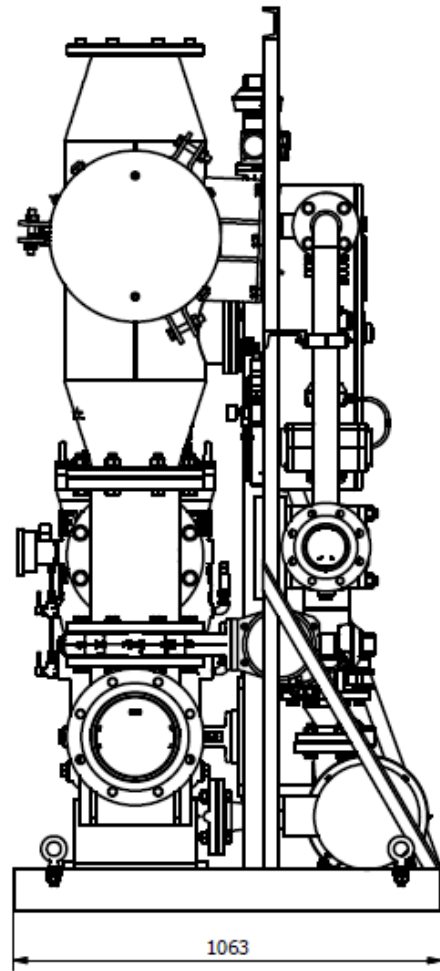
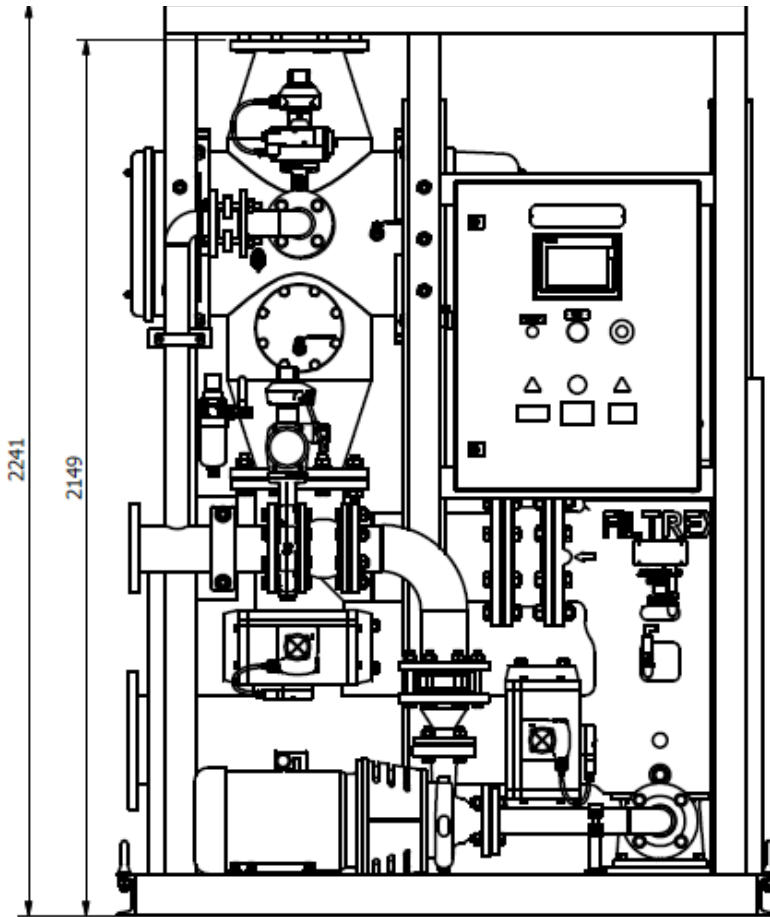

TOP VIEW

